

2C Switching Block XMY-2009 HB with Backpropagation

Table of Contents

1. Introduction	1
2. Features	1
3. Structure	2
4. Function	3
5. Technical Data	3
6. Ordering Data	3

1. Introduction

The APSON 2C Switching Block XMY-2009 HB with Backpropagation belongs to the class of the special switching blocks for 2-components lacquers with hardener. Due to its characteristics it improves the quality and increases the efficiency of the coating process.

This type of switching block is particularly suitable to the employment in automatic coating systems with often to change chemically aggressive media, e.g. lacquers, hardeners, solvents, caustic solutions, a.o. It is applicable both for 2C normal lacquers and 2C metallic lacquers.



APSON 2C Switching Block XMY-2009 HB with Backpropagation

Conventional medium switching blocks for 2-components lacquers are not optimized and have usually channels for supplying the lacquer components and at least one channel for exhaust of the lacquer product. In practice the lacquer product in these channels can harden. This leads to problems during painting and when rinsing the medium switching blocks. Clogged medium switching blocks must be exchanged at expensive timely costs and the medium channels must again be drilled out.

The APSON 2C Switching Block XMY-2009 HB with Backpropagation is equipped with high-quality dead-space-free APSON valve technology and has mixing areas with minimum volume within the ranges within which the master lacquer mixes with the hardener. These mixing areas are optically examinable and fastly cleanable. Hardenings of the lacquer product cannot develop during the normal operation. If this should occur nevertheless, the ready status of the APSON 2C Switching Blocks is restorable in shortest time.

2. Features

The APSON 2C Switching Block XMY-2009 HB with Backpropagation has the following capability characteristics:

- Produces high-quality medium mixture by turbulent pre-mixing of the media already when meeting the media in the mixing area.

- Does not form air columns because the mixing area has no media channels.
- Reaches 100% utilization of material (no hardened medium columns in channels).
- Is environmentally careful due to media recuperation and short rinsing times.
- Is cost-saving due to minimized media consumption.
- Makes possible simple handling when assembling and maintenance.
- Has dead-space-free APSON valve technology.
- Has rinsing- and throughput-optimized media channels.
- Consists of inoxidable steel, thus corrosion resistant and wear resistant.
- Is insensitive to caustic solutions and weak acids.

3. Structure

The APSON 2C Switching Block XMY-2009 HB with Backpropagation consists mainly of:

- A solid valve block with connection- and valve-designations.
- Five APSON valves (see Ordering Data).
- Tube connectors for the connection of the media.
- Output cone with output terminal, backpropagation connection and union nut.
- Optionally two checkvalves (for pulsation air and solvent).
- An attaching bracket.

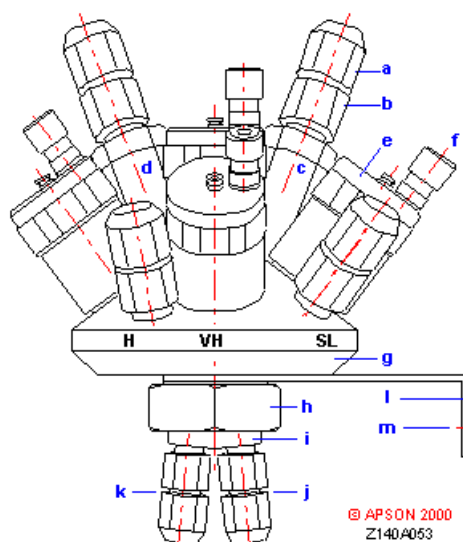

APSON 2C Switching Block XMY-2009 HB with Backpropagation

Legend: a = SL screw nut/mother, b = SL screw connection, c = Checkvalve, d = Checkvalve, e = Valve, f = Pneumatics connection, g = 2C switching block, h = Union nut, i = Output cone, j = 2C-lacquer outlet, k = Feedback, l = Attaching bracket, m = 2 Holes ø7 mm, (horiz. hole spacing 20 mm)

The APSON 2C Switching Block XMY-2009 HB with Backpropagation is made of inoxidable steel and is fastened by means of the attaching bracket to a suitable place.

The media hoses are attached by means of the tube connectors at the respective marked media connections for master lacquer (SL), hardener (H), diluant resp. solvent (V/Lo), pulsation air (PL) and feedback (RF). The union nut at the output cone makes possible fast disassembly for purpose of maintenance resp. inspection.

4. Function

The 2C-lacquer product necessary for painting results in the mixing area of the 2C switching block from simultaneous open valves for master lacquer and hardener. The 2C-lacquer product then flows through the outlet A of the 2C switching block and through a Mixer/Homogeniser which can be connected at the outlet.

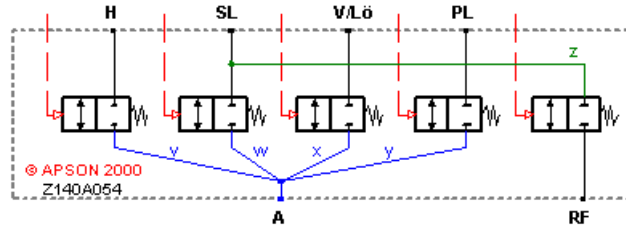

APSON 2C Switching Block XMY-2009 HB with Backpropagation - Functional Scheme

Channel lengths: $L_v = L_w = L_x = L_y = 0.2 \text{ mm}$; $L_z = 1.0 \text{ mm}$

Channel volumes: $V_v + V_w + V_x + V_y = 0.2 \text{ ml}$; $V_z = 0.01 \text{ ml}$

For changing the lacquer, the master lacquer in the lacquer hose can be pushed out through the exit (RF) by opening the feedback valve, and so to be gained back for re-use. Subsequently the lacquer hose for the master lacquer is to be rinsed, as well as the 2C switching block.

For rinsing the 2C switching block, the valves for master lacquer (SL) and hardener (H) are to be closed. Subsequently, the valves for the solvent (V/Lo) and for the pulsation air (PL) are to be opened and closed periodically and alternating. Thus an air/solvent sequence results as follows: air-solvent-air-solvent...

5. Technical Data

Denomination:	APSON 2C Switching Block XMY-2009 HB <i>with</i> Backpropagation
Media:	Normal and metallic lacquers, hardener, solvent, caustic solutions, a.o.
Media pressure:	Max. 20 bar
Valve assembly:	APSON 2/2-Ways Valves 2009, dead-space-free valve technology
Material:	Inoxidable steel
Seals:	Viton™, or in accordance with customer's request
Media entrances:	For hose D = 8 mm, d = 6 mm (or in accordance with customer's request)
Output terminal:	For hose D = 8 mm, d = 6 mm (or in accordance with customer's request)
Dimensions, L x W x H [mm]:	Without valves: 70 x 70 x 45 With valves: 140 x 140 x 120
Mass:	1.3 kg (with valves)

6. Ordering Data

Denomination	Quantity	Part-Nr.
--------------	----------	----------

APSON 2C Switching Block XMY-2009 HB <i>with</i> Backpropagation (with valves, attaching brackets and SL screw connections)	1	050-A046
APSON 2/2-Ways Valve 2009 (sparepart)	5	060-A013
APSON Mixer/Homogeniser	1	200-0270
APSON Gasket Kit (sparepart)	1	300-0021
APSON Checkvalve for the connection of pulsation air and/or solvent (option)	2	100-A004

Options

Other materials or capability characteristics on customer's request against surcharge.

APSON Lackiertechnik GmbH · Am Wiesengrund 15 · D-63075 · Offenbach · Germany
Phone: +49-69-82-369-447 · Mobile: +49-171-373-1633 · Fax: +49-69-82-369-448
email@apson.de · www.apson.de